

2 1

B

B

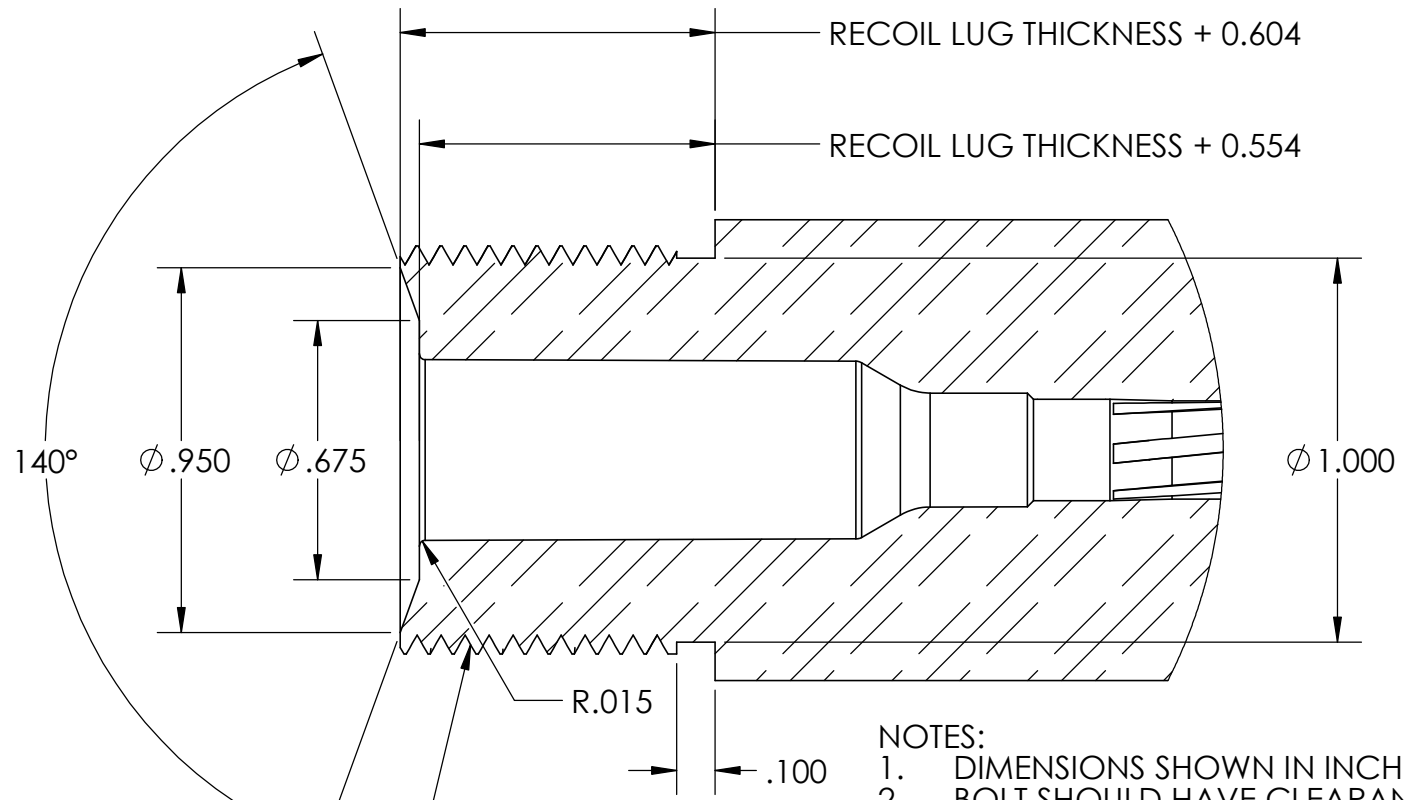

1.0625-16 UN 2A
PITCH ϕ 1.0154 - 1.0204

- NOTES:
1. DIMENSIONS SHOWN IN INCHES
 2. BOLT SHOULD HAVE CLEARANCE TO BREECH FACE OF .002" MIN .005 MAX
 3. RECOIL LUG PROVIDED TO BE MEASURED TO ENSURE ACCURATE DIMENSIONS.
 1. SUPPLIED LUG NOMINAL THICKNESS 0.216"
 4. SUPPLIED DRAWING IS FOR REFERENCE ONLY. BARREL FITMENT TO BE DONE BY QUALIFIED GUNSMITH ONLY.
 5. BARREL TORQUE - 65 FT-LBS

A

A

DRAWN BY: EMS	DATE: 9-19-24	UNLESS OTHERWISE SPECIFIED: DIMENSIONS ARE IN INCHES TOLERANCES: ANGLE \pm .5 EDGE BREAKS .05/.010 TWO PLACE DECIMAL \pm .01 THREE PLACE DECIMAL \pm .005 FOUR PLACE DECIMAL \pm .0005
CHECKED BY:	DATE:	MATERIAL
APPROVED ENGINEERING:	DATE:	FINISH
APPROVED MANUFACTURING:	DATE:	THIS DRAWING CONFORMS TO ASME Y14.5 DO NOT SCALE
APPROVED QUALITY:	DATE:	



PROPRIETARY AND CONFIDENTIAL		TITLE: TENON DIMENSIONS FOR GUNSMITHING	
THE INFORMATION CONTAINED IN THIS DRAWING IS THE SOLE PROPERTY OF BLACKPOWDER PRODUCTS, INC. ANY REPRODUCTION IN PART OR AS A WHOLE WITHOUT THE WRITTEN PERMISSION OF BLACKPOWDER PRODUCTS, INC. IS PROHIBITED.			
SIZE A	DWG. NO.	REV 01	SHEET 1 OF 1

2

1